

AT6105 Spectrometric System for Radiation Monitoring

AT6105 system architecture

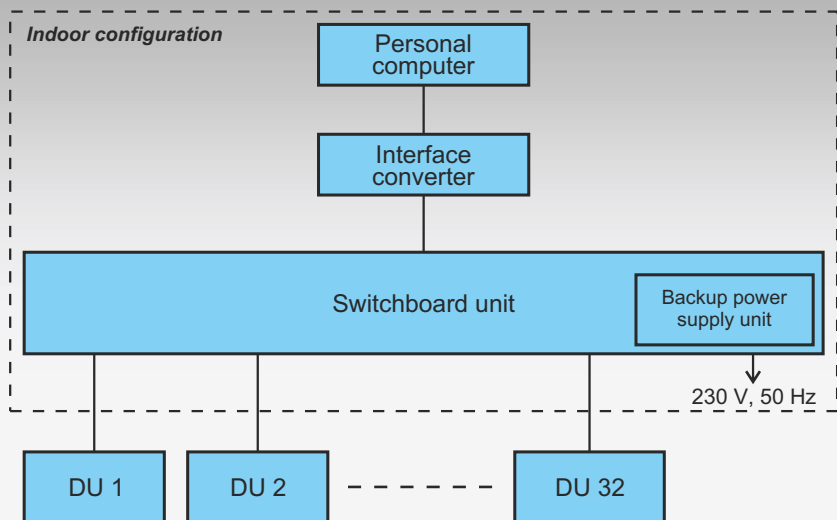

This stationary system is designed for continuous and uninterrupted dosimetric and spectrometric radiation monitoring of land, facilities, wells and other sites.

The System is a network of interconnected gamma radiation detection units with connection to PC. Detection units are monitored and controlled by "SSRM" software to collect and display all measurement data on PC screen.

No switchboard unit is used for single-channel variant (AT6105 with one detection unit).



Operating principle

AT6105 operating principle is based on intermittent reading of dose rate measurement result and instrument spectrum of gamma radiation for each detection units in the system. The measured spectrum is used to identify the composition of gamma radiation source.

If dose rate value transmitted by the Detection unit exceeds "Alarm" threshold setting or an "alarming" nuclide has been identified (software setting for each detection unit), the system initiates a sound and visual alarm on the PC.

Gamma radiation detection units



Applications

- Well monitoring in radioactive waste disposal sites
- Monitoring of radioactive and nuclear material waste repository areas
- Part of radionuclide certification service
- Induced-radioactivity well survey
- Liquid radioactive waste monitoring

Features

- Separate display of spectra and dose rate data by each detection unit on site plan or terrain map
- Energy range expandable to 5 MeV
- Up to 32 detection units
- Sealed detection unit construction

System functions

- Continuous measurement of gamma radiation spectra in a set period of time
- Measurement of gamma radiation dose rate
- Identification of source radionuclide composition
- Evaluation of exceeded dose rate threshold
- Activation of sound and light alarm when threshold levels are exceeded or monitored radionuclides are identified
- All data stored in a log and event history
- Test of detection unit operation
- Detection unit stabilisation by check sample



ATOMTEX[®]

INSTRUMENTS AND TECHNOLOGIES FOR NUCLEAR MEASUREMENTS AND RADIATION MONITORING

AT6105 Spectrometric System for Radiation Monitoring

System specification

Number of detection units	1 ... 32
Maximum communication line distance between detection units and PC	1000 m
Maximum communication line distance between switchboard unit and PC	100 m
Identified radionuclides	Medical ▪ Industrial ▪ Natural
Optional services	Library of identified radionuclides can be modified
Initialisation time	≤1 min
Continuous run time	24 h for AC supply, 110-230 V, 50-60 Hz; 6 h for self-contained power supply from fully charged battery pack
PC interface	USB / Bluetooth (via interface adapter)

System detection units specifications

Gamma radiation detection units	BDKG-201M	BDKG-203M	BDKG-205M	BDKG-211M
Detector	Scintillation, NaI(Tl) Ø25x16 mm	Scintillation, NaI(Tl) Ø25x40 mm	Scintillation, NaI(Tl) 40x40 mm	Scintillation, NaI(Tl) Ø63x63 mm
Energy range	20 keV – 3 MeV	20 keV – 3 MeV	20 keV – 3 MeV	20 keV – 3 MeV
Measurement range of ambient radiation dose rate equivalent	50 nSv/h – 1 mSv/h	30 nSv/h – 500 µSv/h	30 nSv/h – 300 µSv/h	30 nSv/h – 120 µSv/h
Limit of dose rate measurement intrinsic relative error	±20%			
Energy dependence relative to 662 keV (¹³⁷ Cs)	±20% (for energy range from 40 keV to 3 MeV)			
Typical resolution at 662 keV (¹³⁷ Cs)	8.5%	8%	7.5%	7.5%
Sensitivity to gamma radiation	(cps/µSv·h ⁻¹)	(cps/µSv·h ⁻¹)	(cps/µSv·h ⁻¹)	(cps/µSv·h ⁻¹)
²⁴¹ Am	1400	3600	5400	13900
¹³⁷ Cs	165	400	800	2450
⁶⁰ Co	80	190	420	1300
Response time for dose rate change from 0.1 to 1 µSv/h (accuracy error ≤±10%)	≤2 s	≤2 s	≤2 s	≤2 s
Maximum input statistical load	≥10 ⁵ s ⁻¹			
Number of ADC channels	1024			
Radiation overloading	Detection unit withstands 10-fold measurement range upper limit increase for up to 5 min during gamma radiation dose rate measurement			
Burn-up life	≥100 Sv			
Protection class	IP68			
Interface	USB / RS232 / RS485 / Bluetooth (via interface adapter)			
Operation temperature range	-35°C ... +55°C			
Relative humidity	≤98% (with air temperature ≤35°C without condensation)			
Overall dimensions, weight	Ø63x313 mm, 1 kg	Ø63x333 mm, 1 kg	Ø63x333 mm, 1 kg	Ø90x350 mm, 2 kg

Design and specifications are subject to change without notice

“SSRM” “Software

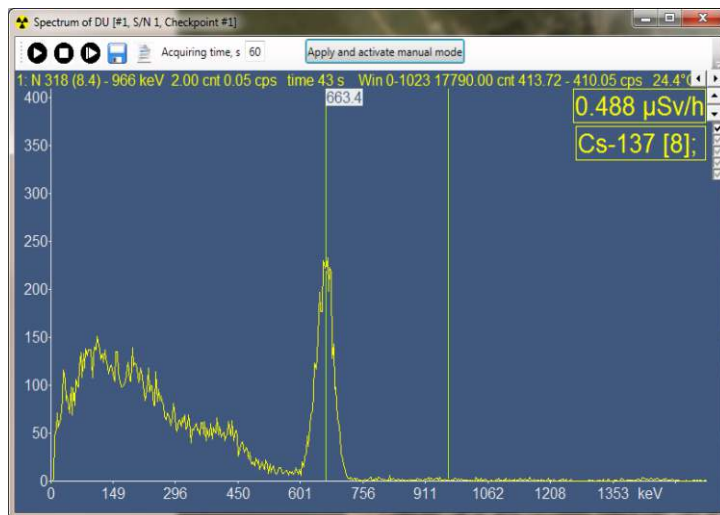

ATOMTEX®
http://www.atomtex.com

5, Gikalo st., 220005 Minsk,
Republic of Belarus
Tel./fax: +375 17 2928142
E-mail: info@atomtex.com



Corporate Member
of European
Nuclear
Society